

## CONGRATULATIONS !

THE **TORTOISE** SLOW MOTION SWITCH MACHINE REPRESENTS THE VERY LATEST IN HIGH TECHNOLOGY DESIGN. UTILIZING A PRECISION GEAR-DRIVE MECHANISM COUPLED TO A MICRO-CURRENT DRAW MOTOR WHICH SAFELY STALLS OUT, CUTOFF CONTACTS AND COIL BURNOUTS ARE A THING OF THE PAST. THE FULLY ENCLOSED CONSTRUCTION WITH OUR ULTRA-SIMPLE MOUNTING AND LINKAGE (INCLUDED) AND THE SIMPLIFIED WIRING WITH AUXILIARY CONTACTS STANDARD COMBINE TO MAKE THE VERY FINEST SWITCH MACHINE AVAILABLE AT ANY COST.

### CONTENTS OF BOX:

- (1) TORTOISE
- (1) Molded Fulcrum
- (1) 3.5" Spring Wire
- (1) 3/8" x #4 Phillips Retaining Screw

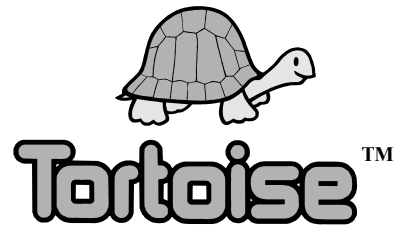

### LAYOUT PREPARATION

The **TORTOISE** is designed to mount under the layout with the spring wire transmitting the linear motion through the layout board and roadbed to the turnout throwbar. Turnouts should be checked for free movement of the points and a clear area under the layout for mounting the machine. Although the **TORTOISE** is extremely forgiving in mounting, a turnout that binds will still not switch smoothly. It will be necessary to provide a hole or slot directly under the throwbar. This hole is typically located between the rails, but may be outside the rails, if desired. The size of this hole should equal twice the total turnout throw (1/4" works well for HO and S). In addition, a small hole will have to be drilled in the throwbar for the spring wire to pass through. Some turnouts have a rivet in the throwbar which can be used for this purpose. If the turnout is already mounted, we suggest drilling a small (.032" - .040") pilot hole through the center of the throwbar and down through the roadbed and baseboard. Next determine the total thickness of the roadbed and board and mark the 1/4" bit with tape or use a drill stop. Then, using the pilot hole as a guide, drill up through the base and roadbed, being extremely careful not to break through and destroy the throwbar. It may be possible to flex the throwbar away from the roadbed slightly to help prevent this. Finally, use a hobby knife to remove any remaining roadbed and to clean up the hole.

### TORTOISE PREPARATION

The 3.5" x .025" spring wire provided with the **TORTOISE** is suitable for layouts having a total roadbed/baseboard thickness of one inch or less. If your layout thickness is greater than 1", you will have to substitute a suitable length of .025" spring wire for the one provided. If greater tension on the points is desired (for O Scale and larger), you may substitute a heavier gauge wire. The output arm will have to be drilled out with a suitable diameter bit held in a pin vise. **CAUTION: DO NOT USE A POWER DRILL!**

1. Prepare the spring wire by gripping it with pliers 1/8" from one end and make a sharp 75-80 degree (nearly right angle) bend. At a point 3/4" away from the initial bend, make an additional 15 degree bend in line with the first. Figure 1 is full size and may be used as a guide.
2. Using a #1 Phillips screwdriver, carefully thread the small phillips head retaining screw into the large hole in the throwarm. *DO NOT PUSH ANY HARDER THAN NECESSARY ON THE ARM!* After the screw bottoms out, remove it. It will be reinstalled after the **TORTOISE** is mounted.
3. Slide the fulcrum into the fulcrum rails on the front face of the **TORTOISE** so that the larger openings of the tapered pivot holes face the bottom.

### MOUNTING

Cut out the template and use a punch or hobby knife to make a hole in the center of the large black dot. The **TORTOISE** can be mounted off centerline if necessary for special clearance applications, in which case one of the two dotted alternate circles should be used. (This changes the geometry of the spring wire, though. Request Application Note AN-6000-01.) Tape the template to the underside of the layout with the hole you just made centered over the 1/4" hole previously bored through the layout. **NOTE:** The large arrow should be parallel to the rails. Drill pilot holes for #4 wood or sheet metal screws at the four points indicated (3/32" or #42 drill bit). Remove the template and fasten the **TORTOISE** to the layout with #4 x 1/2" wood or sheet metal screws. The hole in the fulcrum should be centered directly under the hole in the layout.

**ALTERNATE METHOD:** Use the template as above, but instead of drilling pilot holes, merely mark their location with a punch or nail. Remove the template and sand the wood lightly to provide a clean surface. Spray the area with lacquer to seal the wood. Let dry overnight. Apply double faced foam tape (available at hardware stores) to the entire top surface of the **TORTOISE**. Remove the backing from the tape, and using the punch marks as locating guides, press the **TORTOISE** into position. Rock the **TORTOISE** in all directions to ensure a good bond. Finally, run a bead of silicone RTV (bathtub caulk) around the two mounting flanges against the layout. Allow to cure overnight before proceeding. **CAUTION: ALTHOUGH THIS METHOD ADDITIONAL SOUND DEADENING, THE LONGEVITY OF THE TAPE/SILICONE BOND IS LARGELY UNTESTED, AND LONG-TERM SATISFACTORY RESULTS CAN NOT BE GUARANTEED.**

### WIRING

Connections to the **TORTOISE** can be made by inserting light gauge wires through the holes in the printed circuit board. Solder the wires to the pads using rosin core 60% tin, 40% lead solder (available from Radio Shack) and a small 25 - 35 watt pencil type soldering iron. **WARNING: DO NOT USE A HIGH WATTAGE SOLDERING GUN. DAMAGE TO THE PRINTED CIRCUIT BOARD IS NOT COVERED UNDER WARRANTY.** We recommend locating an 8 position terminal block near the **TORTOISE** and running the wires from the **TORTOISE** to it. In this way, any changes in wiring can be made at the terminal block without having to desolder connections on the board. A more costly option is to utilize a 10 position printed circuit board edge connector (available from electronics' distributors - request Application Note AN-6000-04 for specifications and ordering information from one mail-order distributor) which will simply plug onto the **TORTOISE** circuit board.

The connections on the circuit board are numbered 1 - 8 from left to right. Connections 1 and 8 go to the motor. 2, 3 and 4 connect to one of the internal SPDT auxiliary switches which can be used to power the frog, signals, etc. In similar fashion, 5, 6 and 7 make up the other SPDT switch. These auxiliary switches can *switch* a maximum of one (1) amp of current (they can safely carry 4 amps on each contact set) and can switch either AC or DC loads. If you need to switch heavier currents, parallel both sets of contacts or you may connect a relay to the output. Figure 2 shows the internal connections and switch configuration of the **TORTOISE**. (Request Application Note AN-6000-02 for detailed wiring diagrams of turnout frog, relay and signal wiring.)

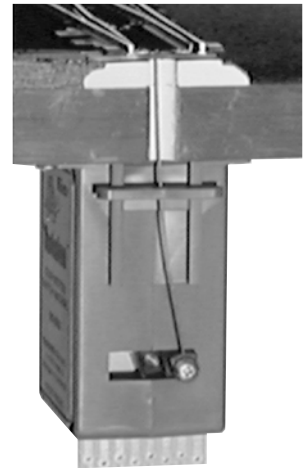

FIGURE 1.

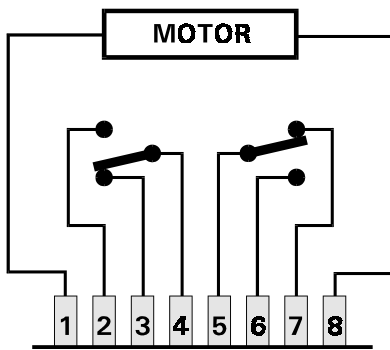
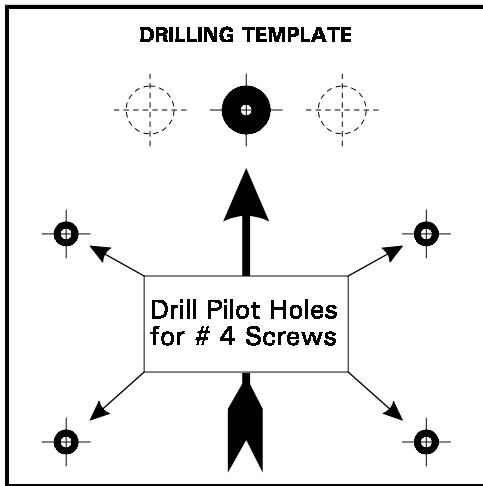

FIGURE 2.

As mentioned earlier, the motor in the TORTOISE is powered continuously and merely stalls out at the end of the throw. The motor will not be harmed by continuous application of 12 volts DC or less. In fact, even if AC is inadvertently applied to the motor terminals (1 and 8), no harm will be done as long as it is 12 volts or less. The TORTOISE will not work with AC, of course, but it will not be damaged. There are basically three different methods of providing the changeable polarity DC necessary to make the TORTOISE run in both directions.

**1. DC WITH CROSS WIRED DPDT SWITCHES:** This system uses the most basic power source, a simple DC supply of not more than 12 volts. Lesser voltages will make the TORTOISE run slower (and quieter). The power supply need not be filtered. Each TORTOISE will draw 15-16 ma. at stall, so 30 switch machines can be powered by a single 9 or 12 volt, 500 ma. wall plug adapter (available from Radio Shack). Any type of DPDT switch (toggle, slide, etc.) can be used to switch the polarity. This system will have two wires running from the control panel to each TORTOISE. See Diagram 1 below.

**2. BI-POLAR DC WITH SPDT SWITCHES:** This system requires two similar DC supplies of not more than 12 volts each. They are wired in series with the (+) of one supply connected to the (-) of the other supply. This common connection feeds a bus wire that

runs around the entire layout. One of the motor connections from each TORTOISE connects to this bus. Single pole switches connect either the (+) supply or the (-) supply to the single wire that runs from the panel to the remaining TORTOISE motor connection. This system offers simplified wiring and the use of lower cost SPDT switches for control. This is offset slightly by the increased cost of the two supplies. See Diagram 2 below.

**3. AC WITH STEERING DIODES:** This system utilizes a standard AC Transformer in conjunction with two diodes to provide half-wave rectified DC to the switch machines. One side of the transformer output feeds a layout bus wire as in (2) above. The other lead from the transformer is connected to two diodes, each of which then powers a panel bus which is connected to the SPDT switches. Note the polarity of the diodes. Only one wire runs from each panel switch to the respective TORTOISE. Since the system is supplying only half-wave DC, the voltage of the transformer should be 14 - 16 volts to compensate. See Diagram 3 below.

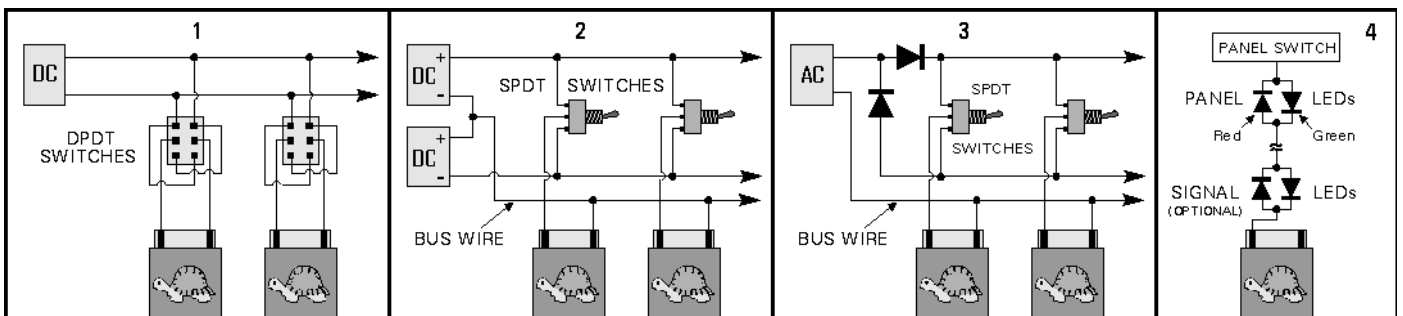

**PANEL LIGHTS / SIGNALS** (See Diagram 4 above or Request Application Note AN-6000-07 for more detailed wiring diagrams)

Although the auxiliary contacts on the TORTOISE may be used to power panel lamps or signals, the low current draw of the TORTOISE allows you to wire Light Emitting Diodes (LEDs) directly in series with the motor. If both red and green (or bi-color) LEDs are wired in reverse parallel, the direction of turnout throw will be indicated without having to run any wiring back to the panel! In addition, the LED will light dimly during the throw but will come up to full brightness when lock-up occurs. There is no limit to the number of LEDs that may be wired in series, but each LED will reduce the voltage reaching the TORTOISE by 2 volts. You may want to increase the supply voltage to compensate.

### FINAL ASSEMBLY / ADJUSTMENT

After the TORTOISE is wired, slide the straight end of the spring wire up through the fulcrum and through the hole in the throwbar. Insert the bent end into the small hole in the TORTOISE throwarm. Re-install the phillips retaining screw and tighten it down until it *LIGHTLY* contacts the wire. **DO NOT OVERTIGHTEN!** Test the operation under power. **DO NOT TRY TO MOVE THE THROWARM BY HAND EXCEPT WITH EXTREME CARE! DAMAGE TO THE GEARS MAY RESULT!** Check the tension on the points and adjust the fulcrum, if necessary, to achieve the desired tension and throw. Fix the position of the fulcrum with a small spot of RTV (Silicone caulk). If the TORTOISE runs (crawls?) in the wrong direction when power is applied, interchange the motor connections (1 and 8).

### LIMITED

CIRCUITRON warrants the TORTOISE against defects in materials and workmanship for a period of nine (9) years from the date of purchase. CIRCUITRON will repair or, at its option, replace those components that prove defective, provided the product is returned (properly packed and shipping prepaid) directly to the factory. This warranty covers all defects incurred in normal use of the TORTOISE and does not apply in the following cases:

1. If damage to the device results from abuse, mishandling, accident or failure to follow instructions.
2. If failure of the auxiliary switching contacts results from application of current loads exceeding the ratings.
3. If either the product label or date stamp label have been damaged, altered or removed.
4. If the product has been used for a purpose other than that intended or in a commercial or club layout.

Requests for warranty service must include a dated proof of purchase, a written description of the nature of the problem and \$3.00 US for shipping and handling (outside the US, include \$5.00 US).

EXCEPT AS PROVIDED ABOVE, NO OTHER WARRANTY OR GUARANTEE, EXPRESS OR IMPLIED INCLUDING MERCHANTABILITY, ON THE PART OF CIRCUITRON OR ANY OTHER PERSON, FIRM OR CORPORATION, APPLIES TO THIS DEVICE.

CIRCUITRON, INC., 211 RocBaar Drive, Romeoville, IL 60446